

Features and Benefits

ANTRONIX®

1.2 GHz Line Equalizer w/Plug-in LEQ-PCM Mid-Split Diplex 85/102 MHz

The LEQ-PCM equalizer provides 12 amperes of current capacity and the flexibility of both a forward and a reverse path signal conditioning plug-in. The flexibility of an additional forward equalizer allows for easy system redesigns. System studies have shown that the addition of reverse band attenuation in strategic locations provides optimal support of reverse band services. Various plug-in combinations are available to accommodate the forward and reverse path equalization requirements of any system.

Antronix has designed the LEQ-PCM to withstand the most severe environmental conditions with the multi-step painting process. Additionally, the LEQ-PCM can withstand 6 kV combination wave surge per IEEE C62.41 Category B3.



- **Separate Plug-ins for the Forward and Return Paths**
- **6 kV Combination Surge Withstand on Input/Output Ports**
Surge withstand per IEEE C62.41 Category B3.
- **Forward Path Plug-in**
Allows the system designer to make adjustments to the system design equalizing only the forward path while adding minimum reverse path loss.
- **Reverse Path Return Plug-in**
The reverse path can be optimized by adding a plug-in reverse path attenuator. By adding attenuation in the reverse path, return signals such as cable modems can be operated at higher levels for improved signal-to-noise performance while preventing clipping and distortion in the optical return laser.
- **Reverse Path Optimization**
- **12 Amperes of Power Passing Capability**
12 A @ 90 VAC

Electrical Specifications LEQ-PCM

Model: LEQ-PCM		LE12-08	LE12-12
Equalizer Value (dB)		8	12
Forward Passband	Freq (MHz)	102-1218	102-1218
Return Passband	Freq (MHz)	5-85	5-85
Forward Specifications	Freq (MHz)	Spec	Spec
Insertion Loss (dB max)	102	8.2±1.0	11.7±1.0
	120	7.5±0.85	10.3±0.85
	250	6.8±0.85	8.7±0.85
	550	4.6±0.85	5.3±0.85
	750	3.1±0.75	3.2±0.85
	870	2.2±0.75	2.4±0.85
	1002	1.6±0.75	1.7±0.75
	1218	2.0±0.75	2.0±0.75
Return Loss (dB min)	102-1218	16	16
Group Delay (nS max/3.58 MHz)	Ch. EIA 97	20	20
	Ch. EIA 98	10	10
	Ch. EIA 99 & up	5	5
Hum Modulation @ 10 A (dBc)	102-1218	-60	-60
Return Specifications	Freq (MHz)	Spec	Spec
Insertion Loss (dB max)	5	1.0	1.0
	45	1.0	1.0
	85	1.7	1.7
Return Loss (dB min)	5-10	12	12
	11-30	13	13
	30-85	16	16
Group Delay (nS max/1.5 MHz)	5.0-6.5	40	40
	6.5-8.0	20	20
	8.0-9.5	10	10
	9.5-80.5	7	7
	80.5-82.0	10	10
	82.0-83.5	15	15
83.5-85.0	20	20	
Hum Modulation @ 10 A (dBc)	5-85	-55	-55

LEQ-PCM Block Diagram

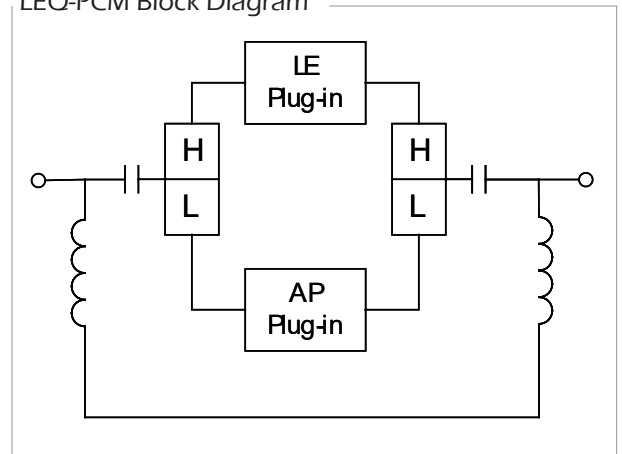

Specifications LEQ-PCM

General	
Power Passing	12 amps @ 90 VAC
Nominal Impedance	75 Ω
Operating Temperature	-40 °C to 60 °C
Pressure Seal	15 psi
Surge Withstand	6 kV Combo Wave (IEEE 62.41-1991 Cat. B3) 6 kV Ring Wave (IEEE 62.41-1991 Cat. A3)

Ordering Information

LEQ-PCM-LE 12-XX-AP XX /U

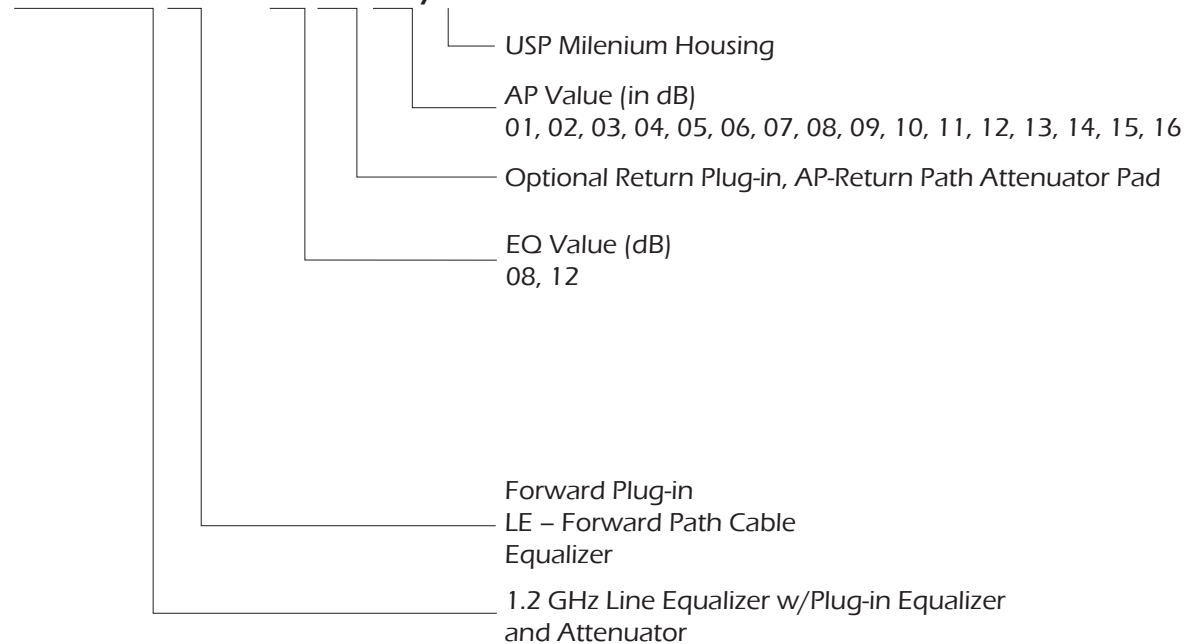

For Example:

LEQ-PCM/U	Line equalizer includes one forward jumper plug-in and one reverse jumper plug-in with a USP housing
LEQ-PCM-LE12-08/U	Line equalizer includes one forward 08 dB/1.2 GHz equalizer plug-in and one reverse jumper plug-in. Also includes USP housing.

Plug-in conditioners:

LE12-**	1.2 GHz plug-in equalizer; 08 dB or 12 dB
AP**	Return attenuator (select one): 00–16